

# DRAWWORKS INSTALLATION CHECKLIST

## MECHANICAL INSTALLATION

## STEP

ENCODER	1
TETHER	1
THREE #10-32 X 3/8" BUTTON SCREWS	1
1 ¼" OPEN-ENDED WRENCH *	4
ONE MOUNTING BOLT	6
SCREWDRIVER(S) / WRENCH(S) *	1, 6



**DO NO USE  
TOOTHED  
WRENCHES**

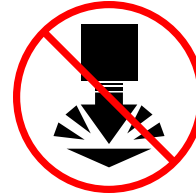

**DO NOT DROP  
ENCODER**



**DO NOT OVER  
LOAD  
ENCODER**

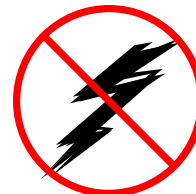

**TURN OFF  
POWER TO  
CABLE AND  
SHAFT**

## ELECTRONICS INSTALLATION (OVER)

## STEP

5/32" HEX KEY *	1,10
SMALL FLATHEAD SCREWDRIVER *	2,7
CABLE SEAL *	2,4,6
DATA/POWER CABLE *	8

\* NOT SUPPLIED BY BEI

These commodities, technology or software if exported from the United States must be in accordance with the Bureau of Industry, and Security, Export Administration regulations. Diversion contrary to U.S law is prohibited.

# Mechanical Installation

<http://www.beiied.com/PDFs2/HSInstallation.pdf>

1. Attach the tether to the encoder housing.

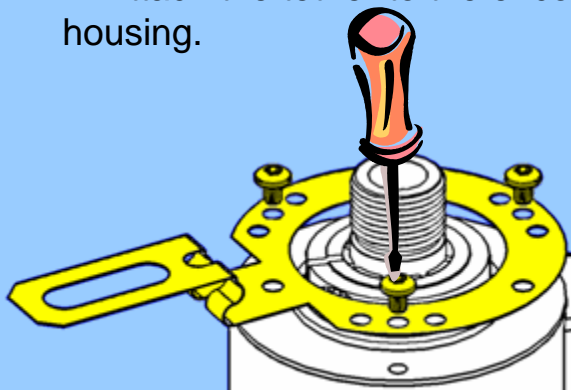

2. Apply anti-seize compound to the encoder mating threads.

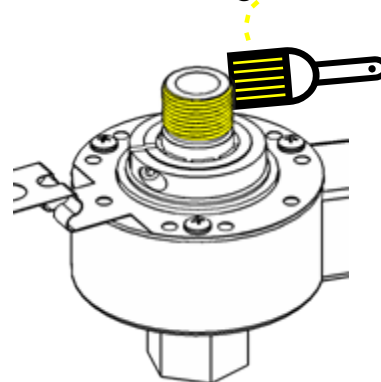

3. Screw the encoder onto the mating shaft.

4. Secure the shafts together.

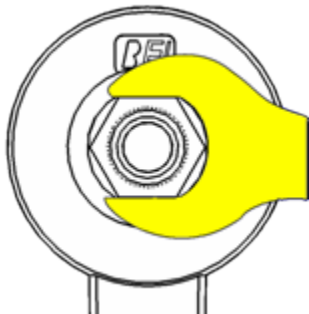

5. Align the tether slot with the mounting point.

6. Fasten the tether, thru the slot, to the mounting point.

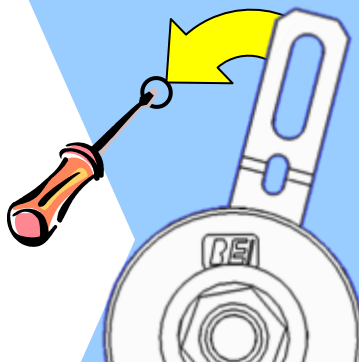

Shaft run out may increase wear on the encoder bearings.

# Electrical Installation



Static sensitive components:  
take appropriate precautions

1. Remove cover screws, terminal cover plate, and O-ring.



Loose components, do not lose!

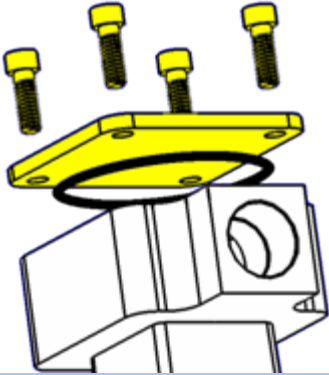

2. Install cable seal.

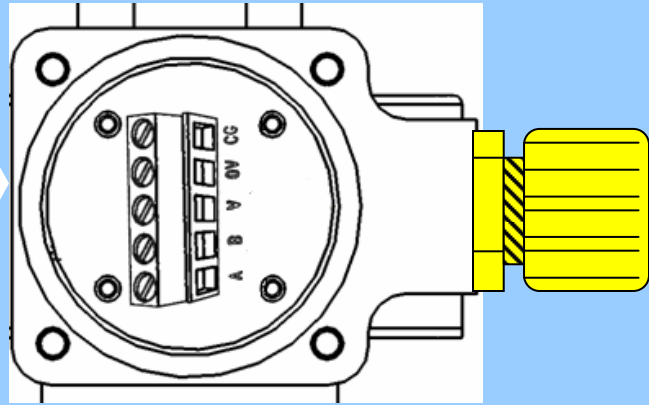

3. Touch the cable shield to a grounding surface (such as a metal frame).

4. Push the end of the cable through the cable seal.

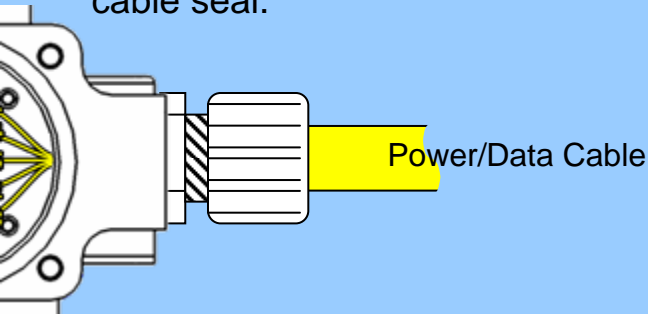

5. Secure each wire in the order shown below.

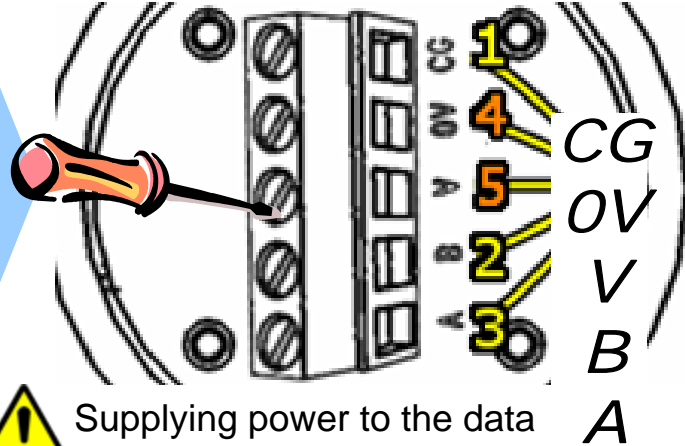

Supplying power to the data terminals may damage the encoder.

6. Tighten cable seal per manufacturer's specifications.

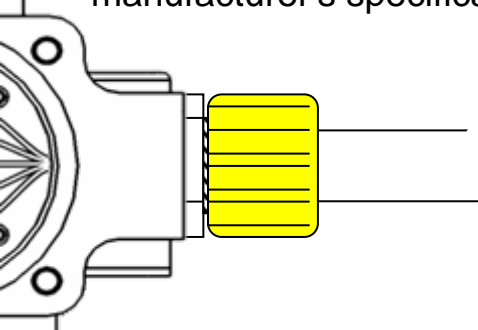

7. Replace the O-ring, terminal cover plate, and cover screws.

8. You may now safely power the encoder.

