

ENCODER TESTER ELECTRONIC MODULE



This test module accepts input from any type of incremental optical encoder. It tests for two channels in quadrature, an index pulse, and power to the module. It features a simple and intuitive LED indicator scheme: lights are on to indicate that a signal is HI and off when the signal goes LO. At full speed operation, the A and B channel LEDs will blink so rapidly that they will appear to be continuously lit and the index channel will flicker. To see the ON-OFF operation of the LEDs just turn the encoder slowly by hand. Through combinations of terminal connections and dropping resistors (supplied), it can test open collector outputs, and both single ended and differential outputs at all standard voltages: 5VDC, 12-15 VDC, and 24 VDC. This tester can also be used for machine set-up (by locating the index pulse) and incoming inspection and diagnostics of encoded motors.

ELECTRICAL SPECIFICATIONS

POWER:

The encoder tester uses an internal voltage regulator. It is powered by an external power supply of 4.5 to 26 VDC. This unit should never be connected directly to AC power mains. The test module draws approximately 75 mA and a green LED indicates the unit is powered. The encoder under test must also be connected to a power supply (Power supply not included).

SIGNAL:

The encoder tester is designed around the most common type of encoder output – a TTL level (RS422) differential line driver. However, it can be used to test most encoder signal types with the proper connections. Please follow the connection diagrams and the table as detailed in the specification sheet for the type of encoder signal that you will be testing.

MECHANICAL SPECIFICATIONS

Package dimensions are 114.4 mm high by 99 mm wide by 22.5 mm thick. The package mounts to a DIN rail type EN 50 022 (35mm X 7.5mm). A length of DIN rail is supplied with each tester. The DIN rail section can be mounted directly to the back of a bench test stand with standard sheet metal or wood screws. The tester simply snaps directly to the DIN rail and is ready to use.

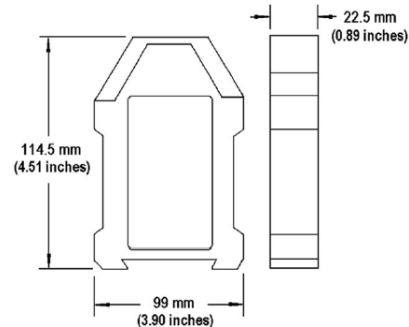

Output Code Format From Encoder	Dual Channel in quadrature with index and complements. Data lines are designated A, B, Z, A-, B-, Z- at the module
Output Signal Type From Encoder	TTL level (RS422 compatible) differential line driver (Use Connection Instructions #1) TTL level (RS422 compatible) single ended line driver (Use Connection Instructions #1) Single ended open collector with pull-up resistors internal to encoder (Use Connection Instructions #2) Single ended, open collector (Use Connection Instructions #3)
Frequency Response of Tester	1 MHz, maximum
Power Requirements For Tester	Input supply voltage 4.5 to 26 VDC, 75 mA (typical)
Protection Level	Supply lines protected against over voltage to 60 volts and reverse voltage

These commodities, technology or software if exported from the United States must be in accordance with the Bureau of Industry, and Security, Export Administration regulations. Diversion contrary to U.S. law is prohibited.

Tel: 805-968-0782/800-350-2727 | Fax: 805-968-3154/ 800-960-2726 | 7230 Hollister Ave, Goleta, CA 93117-2807 www.beisensors.com

Part No. 60002-001 | Specification No. 02125-002

Rev 06/11

BEI SENSORS

NOTE:

1. Encoders do not always have all three channels (A, B, and Z). If a channel fails to light, ensure that the encoder has that channel available. Refer to the BEI *Optical Encoder Design & Specifying Guide* for encoder pinouts and model number information.
2. If the encoder is designed for an output voltage of 12 to 15 volts, then use the 1 kohm dropping resistor provide with the encoder tester. If the encoder is designed for an output voltage of 24 volts, then use the 2.4 kohm resistor supplied with the tester. These resistors are installed in series with the inputs (See Table 1)

Encoder Signal Voltage	Series Resistance, R	Color Code
5V	None	-----
12-15 VDC	1 kohm, 1/2W	BRN – BLK – RED
24 VDC	2.4 kohm, 1/2W	RED – YEL - RED

Table 1

CONNECTION INSTRUCTIONS # 1

Differential or Single Ended Line Driver

Encoder Output Voltages from 5 VDC to 24 VDC

1. Connect the terminals for the encoder tester labeled A-, B-, and Z- to the power supply common from the encoder.
2. Connect the encoder A, B, and Z channels to the terminals marked A, B, and Z, respectively, on the encoder tester. See NOTE 2.
3. Supply input power to tester and verify the green LED is lit. Tester is ready to operate.
4. Power up the encoder.
5. Turn the encoder slowly by hand. The A and B channel LED's should alternately blink on and off with the Z channel lighting up once per complete revolution of the encoder shaft. High resolution (>500 cpt) will blink rapidly. By alternately turning and stopping the shaft, it may be easier to see the on/off operation of the LEDs. If this is not the case, the encoder is faulty and needs to be replaced or repaired. See NOTE 1.
6. If your encoder has complementary signals, A-, B-, and Z- you are now ready to test those channels.
7. Turn off the power to the encoder.
8. Disconnect the encoder's A, B, and Z channels from the tester and connect the encoder's complementary channels in place of those. Connect the encoder's A- channel to the tester's A channel, the B- channel into the tester's B channel and the Z- channel in the tester's Z channel.
9. Power up the encoder and turn it slowly by hand as in step 5 above. Note the operation of the LEDs.

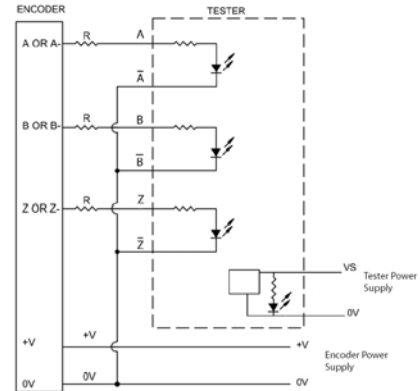

Figure 1

CONNECTION INSTRUCTIONS # 2

Single Ended Open Collector with Internal Pull-up Resistor

1. Connect the terminals for the encoder tester labeled A-, B-, and Z- to the power supply common from the encoder (See Figure 2).
2. Connect the encoder A, B, and Z channels to the terminals marked A, B, and Z, respectively, on the encoder tester.
3. Supply input power to the tester and verify that the green LED is lit. Tester is ready to operate.
4. Power up the encoder.
5. Turn the encoder slowly by hand. The A and B channel LED's should alternately blink on and off with the Z channel lighting up once per complete revolution of the encoder shaft. High resolution (>500 cpt) will blink rapidly. By alternately turning and stopping the shaft, it may be easier to see the on/off operation of the LED's. If this is not the case, the encoder is faulty and needs to be replaced or repaired. See NOTE 1.

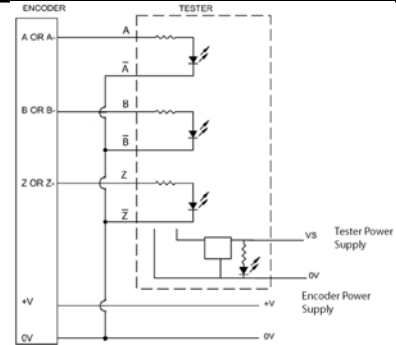

Figure 2

CONNECTION INSTRUCTIONS # 3

Single Ended Open Collector Without Internal Pull-up Resistor

1. Connect the terminals for the encoder tester labeled A, B, and Z to the positive side of the power supply common from the encoder (See Figure 3).
2. Connect the encoder A, B, and Z channels to the terminals marked A-, B-, and Z-, respectively, on the encoder tester. See NOTE 2.
3. Supply input power to the tester and verify that the green LED is lit. Tester is ready to operate.
4. Power up the encoder.
5. Turn the encoder slowly by hand. The A and B channel LED's should alternately blink on and off with the Z channel lighting up once per complete revolution of the encoder shaft. High resolution (>500 cpt) will blink rapidly. By alternately turning and stopping the shaft, it may be easier to see the on/off operation of the LED's. If this is not the case, the encoder is faulty and needs to be replaced or repaired. See NOTE 1.

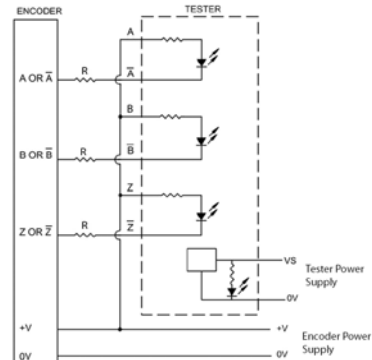

Figure 3